

Features

- ❖ Frequency range: 4.2-5.2 GHz
- ❖ 3D angle range of ± 60 degrees for incidence and reflection
- ❖ Control interface: LAN¹
- ❖ Bi-directional
- ❖ Modulation and protocol agnostic
- ❖ Support VESA Mount Standard
- ❖ Tiling up to a large RIS²
- ❖ Fast Pattern Switch (μs)³



Applications

- ❖ Expanding Sub-6GHz network coverage to reach underserved areas.
- ❖ Improving signal quality in regions with weak or no Sub-6GHz signal coverage.
- ❖ Employing Multi-beam solutions for simultaneous multi-user support².
- ❖ Establishing secure zones for enhanced security and protection of sensitive data or infrastructure

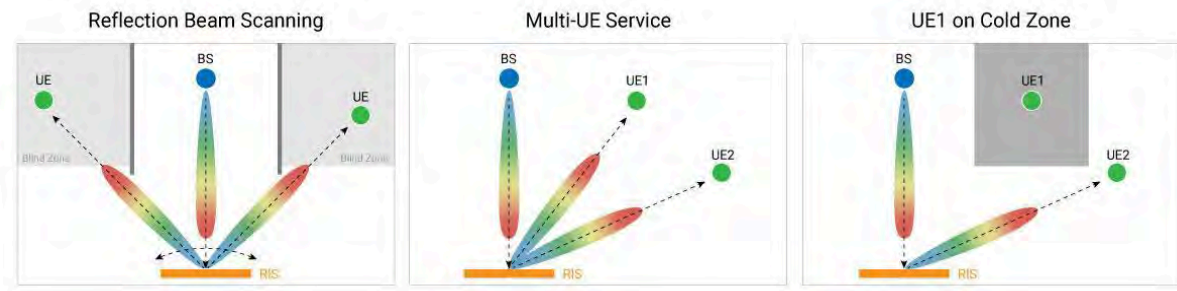

Figure 1. Overview of the Scenario.

Product Overview

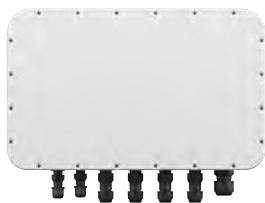

Figure 2. Controller.



Figure 3. RIS 4G7. (Left) w/ Radome. (Right) The Reflection Elements.

¹ It is subjected to changes.

² Planned feature to be released in 2025 Q2.

³ Planned feature to be released in 2025 Q3.

RIS Specifications

Parameter	Conditions	Unit	Typ.
Frequency band	---	GHz	4.2-5.2
Polarization	---		Linear
Number of Antenna Arrays	---		16x16
Antenna Array Dimensions	---	mm	428x431
Angle of Incidence	Vertical	deg	±60
	Horizontal	deg	±60
Angle of Reflection	Vertical	deg	±60
	Horizontal	deg	±60
RCS*1 Gain	Incident angle is 0, 4.7 GHz	dB	44.6-46.7
3 dB Beamwidth	Incident angle is 0, 4.7 GHz	deg	5.2-13.2
Distance from transmitter*2	---	cm	> 90
Power Consumption	Activate all pin diodes	W	5
Dimension	---	mm	510x510x57
Weight	Aluminum	kg	6.9
VESA Mount Standard	---	mm	100x100

*1 RCS: Radar Cross-Section

*1 RCS Gain was affected by different reflection angles

*2 Refer to Deployment Suggestion

Controller Specifications

Parameter	Conditions	Unit	Typ.
Control Interface	---	---	10/100 Mbps Ethernet
Pattern Switching Time	Ethernet	ms	TBC
Power Consumption	Integrated with single RIS unit	W	11
Supply Voltage	---	Vdc	12
Dimension	---	mm	345x215x55
Weight	Aluminum	kg	2
VESA Mount Standard	---	mm	100x100

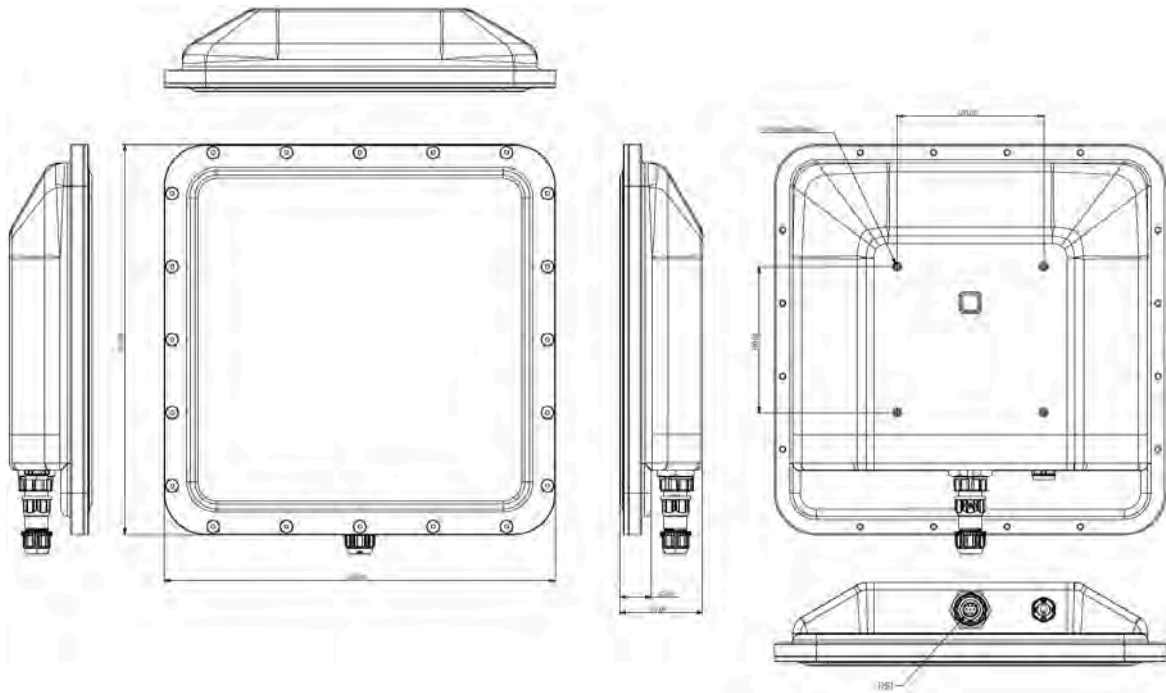

Figure 4. RIS 4G7 Mechanical Drawing.

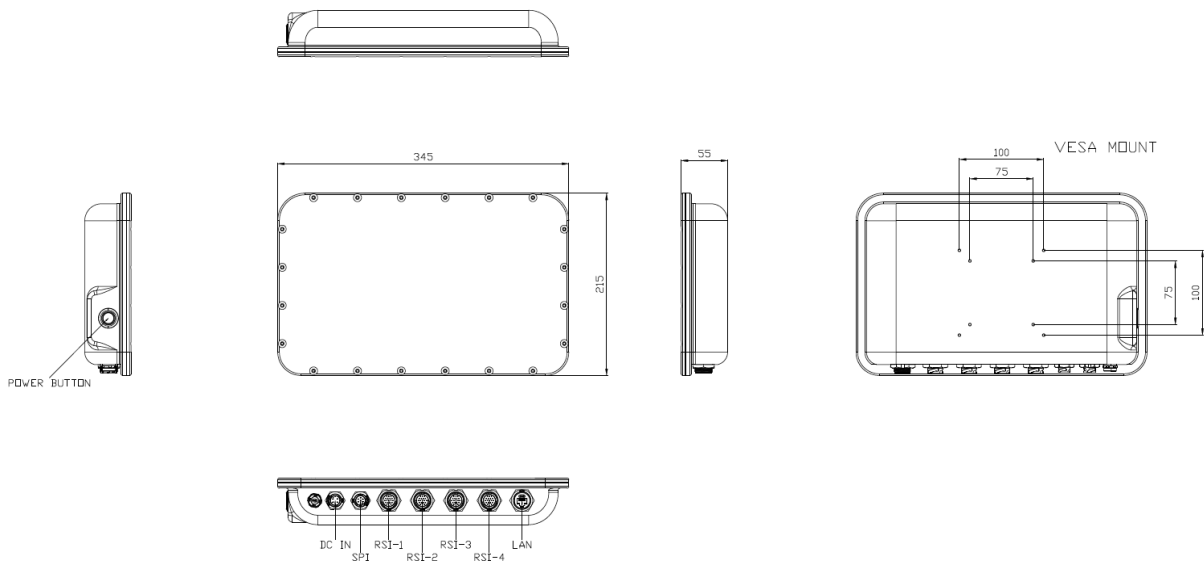

Figure 5. Controller Mechanical Drawing.

Software Control Interface

The Dynamic RIS software interface offers both UI and API control, which are completely designed in-house. Our software algorithm offers better accuracy and easier control of the incident and reflection angles. To control the incident and reflection beam angles, one only needs to drag the red point at the tip of the beam and move it to the desired direction. The user interface also allows users to import and export customized patterns to certify or implement their own RIS algorithms.



Figure 6. TMXLAB Kit - Software GUI for controlling XRifle Dynamic RIS.

Application Guideline

Link Budget Calculation

To calculate the received power at the receiver side while considering air loss and reflection by the RIS when utilizing the TMYTEK XRifle Dynamic RIS, you can utilize the following formula:

$$P_r = P_t - (path\ loss)_{transmit\ to\ reflector} + G_{RCS} - (path\ loss)_{reflector\ to\ receiver} + G_r$$

Where:

- P_r is the received power
- P_t is the transmitting power
- G_{RCS} is the RCS gain provided by XRifle Dynamic RIS, which varied with angles
- G_r is the receiver gain

Example

- The operating frequency is 4.7 GHz
- The RIS is 2 meters from the transmitter, aligned directly (incidence angle: 0°), where path loss is 51.9 dB
- The receiver is 5 meters from the reflector, tilted at 20° (reflection angle: 20°), where path loss is 59.86 dB
- The EIRP of the transmitter: 15 dBm.
- Receiver gain: 15 dB

$$P_{received} = 15\ dBm - 51.9\ dB + 46.7\ dB\ (RCS\ Gain) - 59.86\ dB + 15\ dB = -35.06\ dBm$$

Deployment Suggestion

To ensure optimal utilization of the entire RIS area, the distance between the feed and RIS is described below:

- R_{feed} : Recommended feed distance
- R_f : Far field distance ; $2D^2 / \lambda$
- $R_{HPBW,E}$: 3dB Beamwidth of E plane distance which the power cover the RIS area

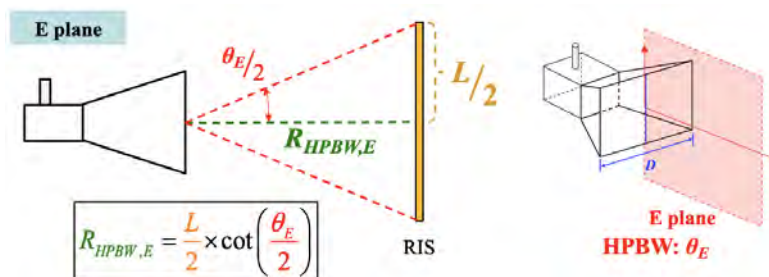

Figure 7. Illustration of Deployment Suggestion.

1. $If R_f > R_{HPBW,E} \Rightarrow R_{feed} \geq R_f > R_{HPBW,E}$
2. $If R_f < R_{HPBW,E} \Rightarrow R_{feed} \geq R_{HPBW,E} > R_f$

Test Performances

The test results of 0 degree incidence angle to various reflection angles ranging from +/-10 to +/-60 degree

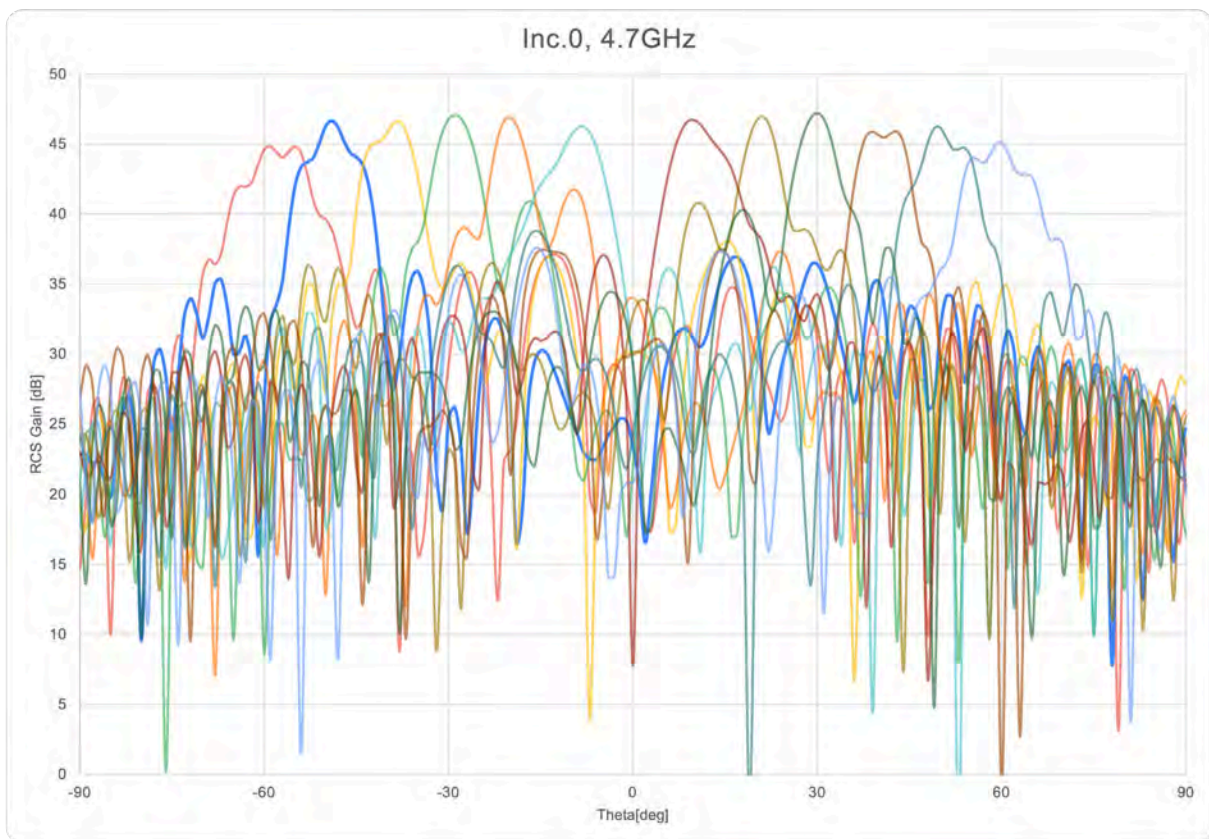

Figure 8. Performance Result.